

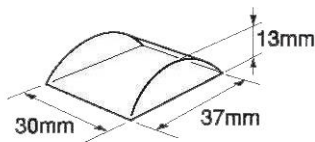

PRODUCT FEATURES

- Produce more quality ice.
- Crystal clear, hard individual uniquely shaped Crescent cubes that last longer in drinks.
- Use less energy.
- Cycle 1/2 as many times as competition.
- Cubes do not clump together in storage bins.
- Unique stainless steel evaporator design which is unaffected by caustic water, harsh cleaning agents and does not crack or peel like nickel plated evaporators.
- Long life stainless steel construction.
- Inbuilt, removable, easily cleaned, reusable.

CRESCENT ICE



SHAPE OF ICE:



TECHNICAL DRAWING

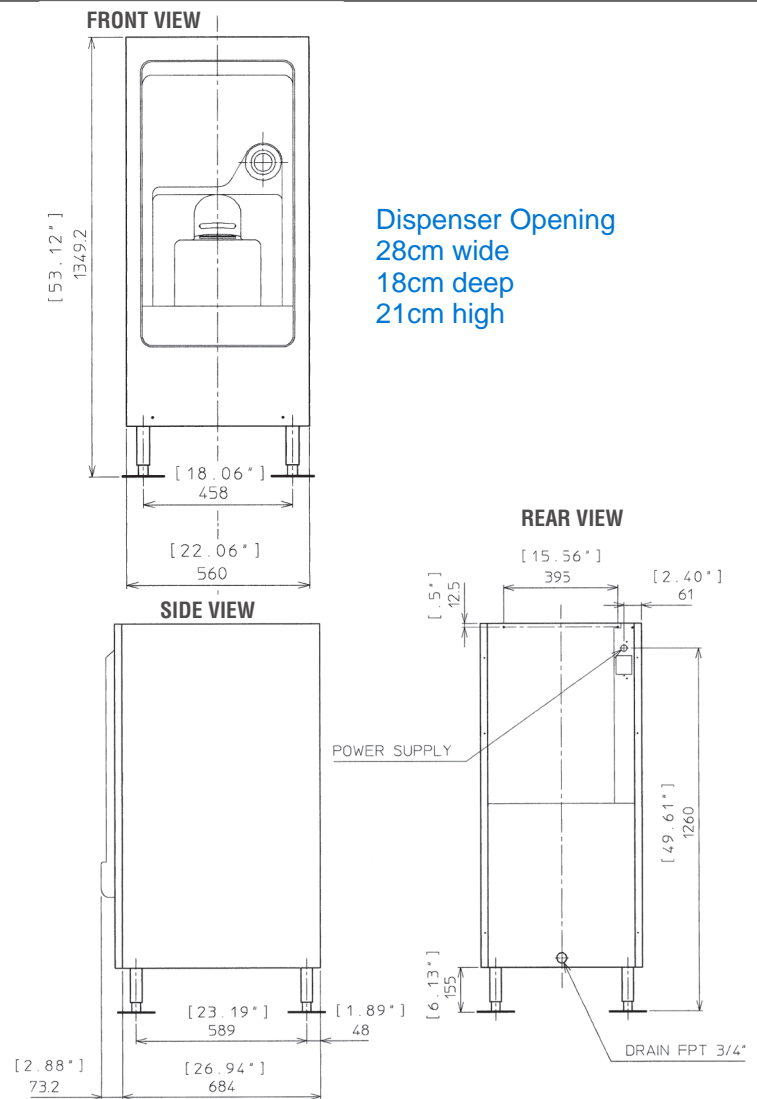

PRODUCT SPECIFICATION

Max Storage Capacity	Approx. 59kg
Dimensions	560mm (W) x 757mm (D) x 1349mm (H)
Dispensing gear motor	60W
Weight Net/Gross (kg)	57
AC Supply Voltage	1 PHASE 240V 50Hz/10AMP Plug
Amperage	Rated:1.4A
Production	Select Modular Head unit KMD-201AB, KMD-270AB or KM-660MAJ-E (Sold Separately)
Operating Conditions	Ambient Temp.: 7-38°C Voltage Range:104 -132V



Descriptions and specifications are subject to change at any time, without notice. Illustrations for demonstration purposes.

Copyright © 2020 Hoshizaki Lancer Pty Ltd. All right reserved. E&OE Date: Sept 2020